

WHAT DO YOU HAVE TO SAY?



HP Designjet L65500 Printer

Print with the environment in mind



Offer outdoor and indoor application versatility with print-quality and display permanence comparable to low-solvent printers. Reduce the impact of printing on the environment. Deliver faster at high print speeds and improve productivity.

Achieve outdoor and indoor application versatility

- Print rich, saturated colors and deliver applications that impress with the six-color HP Designjet L65500 printing system with HP Latex Inks. Astound customers with high-resolution, up to 1200 dpi prints.
- Performance comparable to low-solvent ink—in a water-based ink. HP Latex prints achieve up to three years display permanence unlaminated, five years laminated and provide scratch, smudge, and water resistance comparable to low-solvent inks.¹
- Capitalize on a printing system that delivers great results across a wide range of media and expand your business. Whatever the application—outdoor banners, POP displays, or soft signage²—you will enjoy the same outstanding results.
- Expect impressive results with a new HP large-format media portfolio. Original HP media and the printing system deliver outstanding results every time you print. Achieve both durability and vivid image quality with a new HP media surface treatment.

Reduce the impact of printing on the environment

- Create an improved printing environment for your employees, and attract the business of environmentally conscious customers. Water-based HP Latex Inks don't require special ventilation³ and may reduce regulatory fees or penalties in some regions.⁴

- Gain a competitive edge with odorless prints⁵ that allow placement in Point-of-Purchase areas where odor is a concern.
- Original HP supplies are designed with the environment in mind. Use Original HP recyclable media⁶ and take advantage of the HP Planet Partners program to return the printheads.⁷ And the ink cartridge includes a recyclable cardboard container.⁸
- Designed together, recyclable HP large-format substrates⁹ and the HP Designjet L65500 printing system deliver incredible print quality, consistent performance, and application versatility—and they reduce the impact of printing on the environment.

Deliver high-speed, productive printing

- Deliver more quickly and consistently with two innovative HP technologies. Take full advantage of HP Wide Scan Printing Technology to deliver faster at high print speeds. The HP Optical Media Advance Sensor advances media precisely.
- Provide consistent color from print to print and job to job with HP DreamColor Technologies. Reduce errors, operator intervention, and waste with automated color calibration. You save media, ink, and time—while delivering incredible, consistent color.
- Enjoy greater productivity with low-maintenance, water-based HP Latex Inks. Prints dry inside the printer, so you don't have to wait to finish or deliver them. Reduce interruptions with HP Latex Inks and low-maintenance features.
- Experience a more efficient workflow with the HP Internal Print Server, which enables independent print queue management and manual nesting.

HP Designjet L65500 Printer

Print with the environment in mind

1. Six HP 786 3-liter Latex Designjet Ink Cartridges with recyclable cardboard ink cartridge container[®] design, hot swappable
2. Two integrated heaters
3. Three HP Wide Scan Printheads (each contains 2 colors of ink) with total 31,680 nozzles, 1200 dpi and 12 pl. drop size
4. HP Embedded Spectrophotometer with Advanced Close Loop Color Calibration
5. HP 786 Designjet Maintenance Kit
6. HP Optical Media Advance Sensor
7. Up to 264 cm (104 in) wide with 110 kg (242 lb) media support

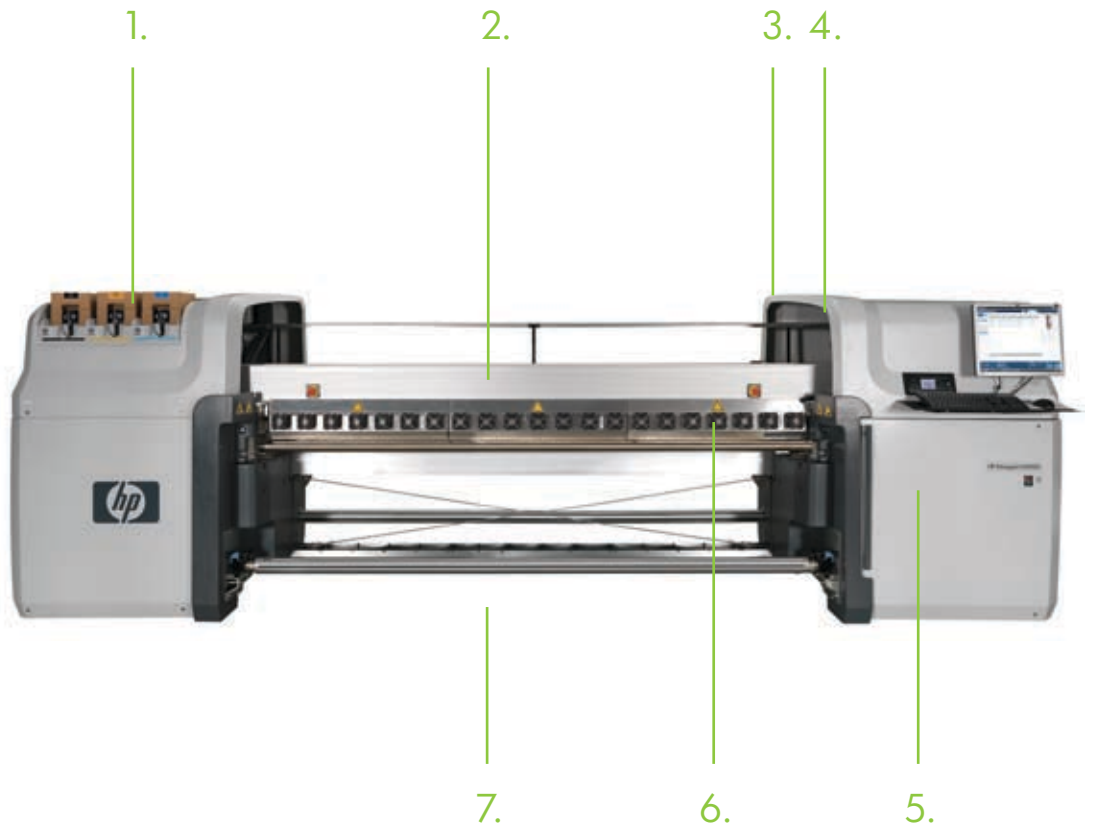

Designed with the environment in mind, HP Latex Printing Technologies offer print service providers a compelling new alternative for creating a wide variety of outdoor and indoor applications. Expand your company's offering with a single, versatile printer that offers broad outdoor and indoor media versatility. Print banners, event and transit signage, vehicle wraps, and other outdoor applications as well as high-quality, indoor signage including point-of-purchase displays.



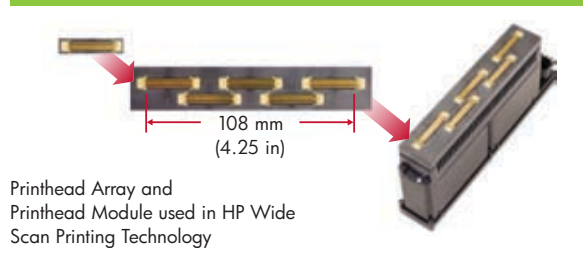

Innovative water-based HP Latex Inks designed with the environment in mind can bring in more business. New HP Latex Printing Technologies offer environmental, health, and safety advantages relative to low-solvent ink technology, that facilitate simpler printer installation and operation on your business premises while providing a breakthrough in meeting the demands of your environmentally conscious customers, all without compromising outdoor durability across a range of substrates.

These innovative new inks do not produce ozone emissions during printing and contain no hazardous air pollutants (HAPs) or sensitizers.⁹

What's more, these inks are non-flammable and non-combustible.

Reach new levels of productivity with HP Wide Scan Technology.

HP Wide Scan Technology delivers high productivity at high image quality using two proprietary HP technologies working together: HP Wide Scan Printheads for precision drop ejection over wide print swaths at high writing speeds, and the HP Optical Media Advance Sensor for accurate media advance between wide print swaths.

The HP Wide Scan Printheads have been designed together with HP Latex Inks for low user maintenance, reliable performance, and maximum productivity. When necessary, individual printheads can be replaced by the user, without the expense, printer downtime, and inconvenience of a service call.

The HP Optical Media Advance Sensor accurately controls media advance to minimize banding for high-quality at high-speed.

Achieve both durability and vivid image quality with a new HP media surface treatment.

Two specially treated HP media, HP DuPont™ Tyvek® Banner and HP High Density Polyethylene (HDPE) Reinforced Banner, provide both image quality and durability when printing with HP Latex Inks. This proprietary new HP media surface-treatment technology produces a wide color gamut and makes it possible to achieve both durability and sharp, vivid image quality on materials that don't typically print well with low-solvent inks.

HP large-format media, HP Latex Inks, and the HP Designjet L65500 Printer are designed and tested together to provide outstanding results every time you print. HP designed 14 new large-format media for optimal results with HP Latex Printing Technologies. This portfolio features 5 recyclable substrates,⁶ including HP High Density Polyethylene (HDPE) Reinforced Banner.

¹ HP image permanence and scratch, smudge, and water resistance estimates by HP Image Permanence Lab. Display permanence tested according to SAE J2527 using HP Latex and low-solvent inks on a range of media, including HP media; in a vertical display orientation in simulated nominal outdoor display conditions for select high and low climates, including exposure to direct sunlight and water; performance may vary as environmental conditions change. Scratch, smudge, and water resistance tested using HP Latex and low-solvent inks on a wide range of HP media; water resistance is comparable when printed on water-resistant substrates. Laminated display permanence using Neschen Solvoprint Performance Clear 80 laminate. Results may vary based on specific media performance. For more information, see www.hp.com/go/supplies/printpermanence.

² For best results, print textile applications on polyester fabric that does not stretch. Performance may vary depending on media. Please consult your media supplier for compatibility details.

³ Special ventilation is not required to meet US OSHA requirements on occupational exposure to VOCs from HP Latex Inks. Ventilation equipment installation is at the discretion of the customer—no specific HP recommendation is intended. Typically no air discharge permitting required with inks that emit extremely low levels of VOCs. Customers should consult state and local requirements and regulations.

⁴ HP Latex Inks may reduce regulatory compliance fees associated with Title V of the U.S. Clean Air Act. Because regulations and fees vary by region, consult your state and local regulations.

⁵ Printers using HP Latex Inks use internal heaters to dry and cure the latex polymer film. Some substrates may have inherent odor.

⁶ Recycling opportunities for this product currently only available in limited areas. Customers should consult local recycling resources.

⁷ Program availability varies. HP printing supplies return and recycling is currently available in more than 45 countries, territories, and regions in Asia, Europe, and North and South America through the HP Planet Partners program.

⁸ Consult with your local authority to determine the appropriate method of waste disposal for the non-hazardous ink bag, aerosol filters, and wet wipe.

⁹ Based on testing conducted in November 11, 2008 that found no detectable Hazardous Air Pollutants (HAPs) per U.S. Environmental Protection Agency Method 311. HAPs are air pollutants which are not covered by ambient air quality standards but which, as defined in the Clean Air Act, may present a threat of adverse human health effects or adverse environmental effects. Such pollutants include asbestos, beryllium, mercury, benzene, coke oven emissions, radionuclides, and vinyl chloride.

HP Designjet L65500 Printer

Technical specifications

Print speed¹⁰	Outdoor-quality prints up to 79 m²/hr (846 ft²/hr)
	Indoor-quality prints up to 34 m²/hr (368 ft²/hr)
Print resolution	Up to 1200 x 1200 dpi
Heater	
Integrated	2 independent heater systems
Locations	Front and print area
Media	
Handling	Roll-to-roll
Types	Supports most low-cost, low-solvent compatible media, as well as a variety of uncoated media: self-adhesive vinyl, banner, film, paper, fabric, mesh, and others
Size	Up to 2.64 m (104 in) wide
Loading	Up to 110 kg (242 lb) rolls, up to 25 cm (9.8 in) outside diameter
Thickness	Up to 0.8 mm (31.5 mil)
Printing	
Technology	HP Latex Printing Technologies
Resolution	1200 x 1200 dpi
Ink type	HP Latex Inks
Ink colors	6 colors (cyan, magenta, yellow, black, light cyan, light magenta)
Ink drop	12 pl
Ink cartridge size	3 liters
Printheads	3 total (each contains 2 colors: cyan/black, magenta/yellow, light cyan/light magenta)
Printhead type	HP Wide Scan Printhead
Nozzles	10,560 per printhead
Outdoor display	Up to 3 years unlaminated, 5 years laminated ¹¹
Indoor in-window display	Up to 5 years unlaminated, 10 years laminated ¹¹
Printing modes	
Indoor	High Quality Plus mode (8 pass): 21 m ² /hr (231 ft ² /hr)
	High Quality mode (6 pass): 28 m ² /hr (306 ft ² /hr)
	Production Plus mode (5 pass, only SAV): 34 m ² /hr (368 ft ² /hr)
	Production mode (4 pass): 43 m ² /hr (460 ft ² /hr)
Outdoor	Billboard Plus mode (3 pass): 55 m ² /hr (587 ft ² /hr)
	Billboard mode (2 pass): 79 m ² /hr (846 ft ² /hr)
	Draft mode (1 pass): 157 m ² /hr (1691 ft ² /hr)
Interfaces	1 Gigabit Ethernet (1000Base-T) port
Dimensions (w x d x h)	5.17 x 1.66 x 1.66 m (16.98 x 5.45 x 5.43 ft)
Weight	970 kg (2138 lb)
Operating environment	
Electrical	Three phase: 200 to 220 VAC (+/- 10%); 380 to 415 VAC (-10% +6%); 50/60 Hz; 32 A max.; single phase: 115 to 127 VAC (+/- 10%); 200 to 240 VAC (-10% +6%) (Japan 200 V); 50/60Hz, 10 A max
Operating temperature	15 to 30° C (59 to 86° F)
Operating humidity	20 to 70% Relative Humidity (non-condensing)
Agency compliance/Certification	
Safety	United States and Canada (CSA listed), EU (LVD and MD, EN60950-1, 12100-1 and 60204-1 compliant), Russia (GOST)
Electromagnetic	Compliant with Class A requirements, including USA (FCC rules), Canada (DoC), EU (EMC Directive), Australia (ACA), New Zealand (MoC)

Ordering Information

Product
Q6702A HP Designjet L65500 Printer

Accessories
CK833A HP Designjet L65500 104-in Spindle
CK832A HP Designjet L65500 Printer Cleaning Kit

Original HP Printheads
CC582A HP 786 Yellow/Magenta Designjet Printhead
CC583A HP 786 Cyan/Black Designjet Printhead
CC584A HP 786 Lt Magenta/Lt Cyan Designjet Printhead

Original HP Ink Cartridges
CC585A HP 786 3-liter Black Latex Designjet Ink Cartridge
CC586A HP 786 3-liter Cyan Latex Designjet Ink Cartridge
CC587A HP 786 3-liter Magenta Latex Designjet Ink Cartridge
CC588A HP 786 3-liter Yellow Latex Designjet Ink Cartridge
CC589A HP 786 3-liter Light Cyan Latex Designjet Ink Cartridge
CC590A HP 786 3-liter Light Magenta Latex Designjet Ink Cartridge

Original HP Maintenance Kit
CC591A HP 786 Designjet Maintenance Kit

Original HP Media Portfolio for HP Designjet L65500 Printer
(NA and EMEA only)

Banners
HP Durable Frontlit Scrim Banner
HP Outdoor Frontlit Scrim Banner
HP Backlit Scrim Banner
HP HDPE Reinforced Banner⁶

Self-adhesives
HP Permanent Gloss Adhesive Vinyl
HP Permanent Matte Adhesive Vinyl

Films
HP Premium Backlit film

Fabric
HP Wrinkle-free Flag with liner⁶
HP Heavy Textile Banner⁶

Paper
HP Blue Back Billboard Paper
HP Photo-realistic Poster Paper⁶

Mesh
HP Mesh Banner with liner

Specialty
HP Satin Canvas
HP DuPont™ Tyvek® Banner⁶

More information on HP Media available at
www.hp.com/go/designjet/supplies

¹⁰ Outdoor-quality speed based on printing using full width (2.64 m/104 in) in two-pass unidirectional print mode; indoor-quality speed based on printing using full width (2.64 m/104 in) in five-pass unidirectional print mode. Five-pass print mode is only available on self-adhesive vinyl substrates.

¹¹ Interior in-window display ratings by HP Image Permanence Lab on a range of media including HP media. HP in-window predictions based on test data under Xenon-Arc illuminant. Calculation assumes 6,000 Lux/12 hr day. Laminated display permanence using Neschen Solvoprint Performance Clear 80 laminate. For more information, see www.hp.com/go/supplies/printpermanence.

© Copyright 2009 Hewlett-Packard Development Company, LP. The information contained herein is subject to change without notice. The only warranties for HP products and services are set forth in the express warranty statements accompanying such products and services. Nothing herein should be construed as constituting an additional warranty. HP shall not be liable for technical or editorial errors or omissions contained herein.

To learn more, visit www.hp.com/go/designjetL65500

4AA1-9598ENW, January 2009

This is an HP Indigo digital print

